

AL24-EE70/C

INSTALLATION INSTRUCTIONS

WARRANTY

Plane Power, Ltd. warrants its alternators and voltage regulators for a two-year period from date of purchase to be in good working order and free of material defects. Plane Power, Ltd. retains the right to rebuild or replace any alternator or voltage regulator if it fails under the terms of this warranty and *only* if the customer's original alternator or voltage regulator is sent to Plane Power for evaluation, along with a dated copy of the sales receipt. This alternator or voltage regulator must be shipped directly to Plane Power per instructions found in this warranty agreement at the customer's expense for warranty evaluation.

If the alternator or voltage regulator is found to have failed under the terms of this warranty, Plane Power will take the appropriate action of either rebuilding or replacing the alternator or voltage regulator. Customers will be responsible for any additional expedited shipping charges. Plane Power, Ltd. reserves the right to insure all alternators and voltage regulators for loss or damage during shipping directly to the customer.

Plane Power, Ltd. makes no warranty as to suitability of its products for the intended application.

To be considered eligible for warranty consideration, **DO NOT PURCHASE A REPLACEMENT ALTERNATOR OR VOLTAGE REGULATOR FROM A DEALER.** Plane Power, Ltd. will not at any time offer a form of a warranty credit for replacement alternators or voltage regulators purchased through a dealer. All warranty claims must be handled directly by Plane Power, Ltd.

If you suspect an alternator or voltage regulator to be defective and in need of service, call Plane Power, Ltd. at 877-934-5700 for a return authorization number.

Alternators and voltage regulators returned to the factory via UPS with the valid return authorization number will usually be rebuilt or replaced the same day as received. However, other carriers and/or circumstances may increase the turnaround to 1-2 days.

Warranty Details

Plane Power, Ltd. warrants its alternators and voltage regulators to be free from defects in material and workmanship under normal use and operation for a period of two years from date of purchase. Plane Power, Ltd. cannot and never will warrant damage to non-alternator or voltage regulator components or related expenses including labor, inconvenience, transportation or loss of business due to any alternator failure.

Plane Power, Ltd. warranty is *void* if:

- An alternator or voltage regulator is improperly installed.
- An alternator or voltage regulator is used for the wrong application.
- Customer tries to service the alternator or voltage regulator in the field by removing or replacing any of the components not specifically instructed and/or supplied by Plane Power, Ltd.
- The alternator or voltage regulator is determined to have failed by application of voltage in excess of the amount specified on the data plate.
- The alternator or voltage regulator is damaged by impact, shock or excessive abuse, (i.e. dents, large scratches, bent components) actual physical evidence not in conjunction with defective components, design or workmanship.

24 VOLT 70 AMP EXPERIMENTAL ALTERNATOR EXTERNALLY REGULATED

NOTE: SAFETY WIRE (2) TENSION ARM BOLTS (MS20074 - 05 - 06 & AN5H-5A) WITH .032" SAFETY WIRE.

REVISIONS

| LTR. | DESCRIPTION | DATE | APR. |
|------|-------------|------|------|
| | | | |

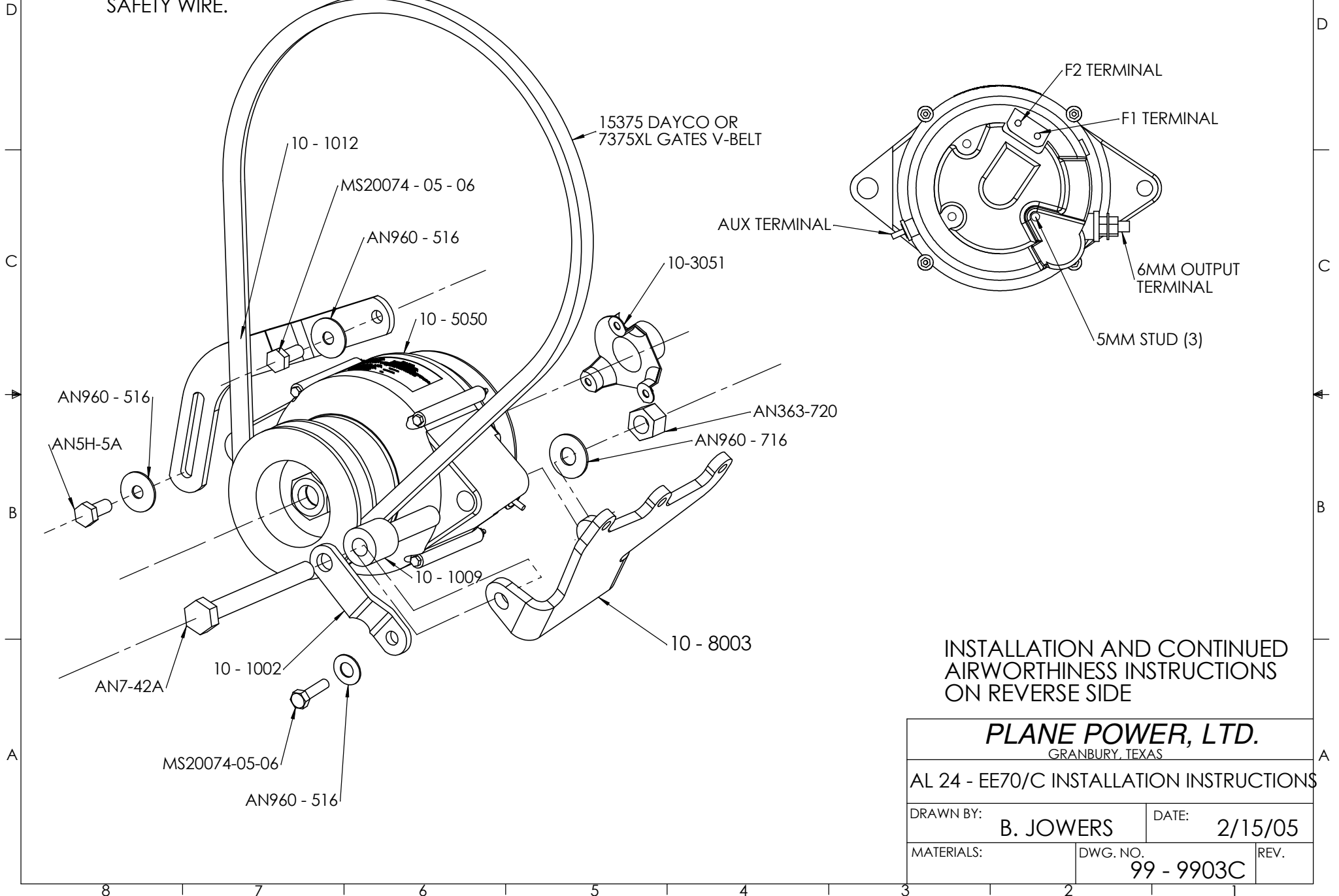

INSTALLATION AND CONTINUED
AIRWORTHINESS INSTRUCTIONS
ON REVERSE SIDE

PLANE POWER, LTD.

GRANBURY, TEXAS

AL 24 - EE70/C INSTALLATION INSTRUCTIONS

DRAWN BY: **B. JOWERS** DATE: **2/15/05**

MATERIALS: DWG. NO. **99 - 9903C** REV.

Part No. 99-9903

Installation Instructions

1. Disconnect aircraft battery.
2. Install alternator per included drawing. Supply outside ram cooling air to the Connector on the rear of the alternator by the use of 1" scat tube.
3. Refer to appropriate engine manual for belt tension and bolt torques.
4. Install battery wire with MS25171-2S terminal nipple on 6mm output terminal and torque to 50 in. lb.
5. Install field wire with MS25171-1S terminal nipple to F1 terminal on rear of alternator and torque to 20 in. lb.
6. NOTE: F2 terminal to remain grounded with ground strap UNLESS aircraft voltage regulator is a type "A" regulator using a 2-wire field circuit, in this case remove and discard ground strap from F2 terminal and connect wiring from voltage regulator to F1 and F2 terminals, torque to 20 in. lb.
7. If aircraft is equipped with an "alternator out light" circuit, connect that wire to the AUX terminal and torque to 20 in. lbs. Other wise leave AUX terminal open.
8. Reconnect aircraft battery.
9. Start engine, enable alternator, and check for proper buss voltage.

Troubleshooting Instructions

Alternator is equipped with a built-in crowbar over-voltage protection circuit which will disable alternator if an over-voltage condition is sensed.

If 5-amp enable circuit breaker trips from an over-voltage condition in the alternator:

1. Reset 5-amp enable circuit breaker and continue operation.
2. If 5-amp enable circuit breaker trips again, land as soon as possible and investigate cause.

Instructions For Continued Airworthiness

Annual Inspections:

1. Remove drive belt and turn alternator rotor to check condition of bearings for abnormal noise or roughness.

5 year or 1,000 hour intervals:

1. Repeat: Annual Inspection.
2. Remove field brush assembly and inspect brushes for excess wear. Replace brush assembly if brushes extend less than .250" from edge of brush holder case.