

12 VOLT 70 AMP EXPERIMENTAL ALTERNATOR EXTERNALLY REGULATED

NOTE: SAFETY WIRE (2) TENSION ARM BOLTS (MS20074 - 05 - 06 & AN5H-5A) WITH .032" SAFETY WIRE.

REVISIONS

LTR.	DESCRIPTION	DATE	APR.

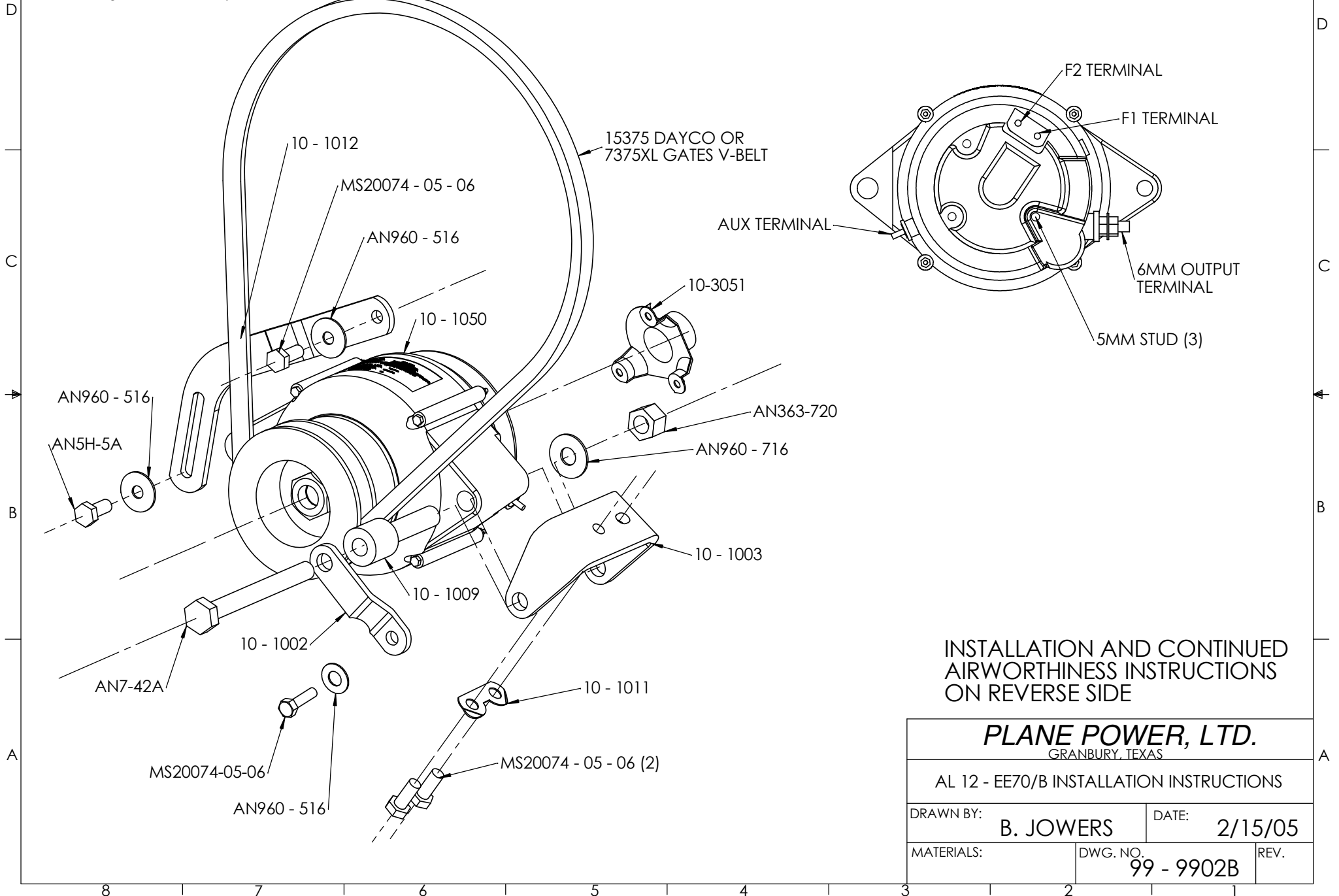

INSTALLATION AND CONTINUED
AIRWORTHINESS INSTRUCTIONS
ON REVERSE SIDE

PLANE POWER, LTD.
GRANBURY, TEXAS

AL 12 - EE70/B INSTALLATION INSTRUCTIONS

DRAWN BY: **B. JOWERS** DATE: **2/15/05**

MATERIALS: DWG. NO. **99 - 9902B** REV.

Part No. 99-9902

Installation Instructions

1. Disconnect aircraft battery.
2. Install alternator per included drawing. Supply outside ram cooling air to the 1" Connector on the rear of the alternator by the use of 1" scat tube.
3. Refer to appropriate engine manual for belt tension and bolt torques.
4. Install battery wire with MS25171-2S terminal nipple on 6mm output terminal and torque to 50 in. lb.
5. Install field wire with MS25171-1S terminal nipple to F1 terminal on rear of alternator and torque to 20 in. lb.
6. NOTE: F2 terminal to remain grounded with ground strap UNLESS aircraft voltage regulator is a type "A" regulator using a 2-wire field circuit, in this case remove and discard ground strap from F2 terminal and connect wiring from voltage regulator to F1 and F2 terminals, torque to 20 in. lb.
7. If aircraft is equipped with an "alternator out light" circuit, connect that wire to the AUX terminal and torque to 20 in. lbs. Other wise leave AUX terminal open.
8. Reconnect aircraft battery.
9. Start engine, enable alternator, and check for proper buss voltage.

Troubleshooting Instructions

Alternator is equipped with a built-in over-voltage protection circuit which will disable alternator if an over-voltage condition is sensed.

If 5-amp enable circuit breaker trips from an over-voltage condition in the alternator:

1. Reset 5-amp enable circuit breaker and continue operation.
2. If 5-amp enable circuit breaker trips again, land as soon as possible and investigate cause.

Instructions For Continued Airworthiness

Annual Inspections:

1. Remove drive belt and turn alternator rotor to check condition of bearings for abnormal noise or roughness.

5 year or 1,000 hour intervals:

1. Repeat: Annual Inspection.
2. Remove field brush assembly and inspect brushes for excess wear. Replace brush assembly if brushes extend less than .250" from edge of brush holder case.