

12 VOLT 60 AMP EXPERIMENTAL ALTERNATOR, W/ INTERNAL VOLTAGE REGULATOR AND OVERVOLTAGE PROTECTION

NOTE: SAFETY WIRE (2) TENSION ARM BOLTS (MS20074 - 05 - 06 & AN5H-5A) WITH .032" SAFETY WIRE.

REVISIONS			
LTR.	DESCRIPTION	DATE	APR.
D	ADDED DAYCO BELT NUMBER	10/9/07	SJK
E	CLARIFIED WIRING DIAGRAM	1/14/07	SJK

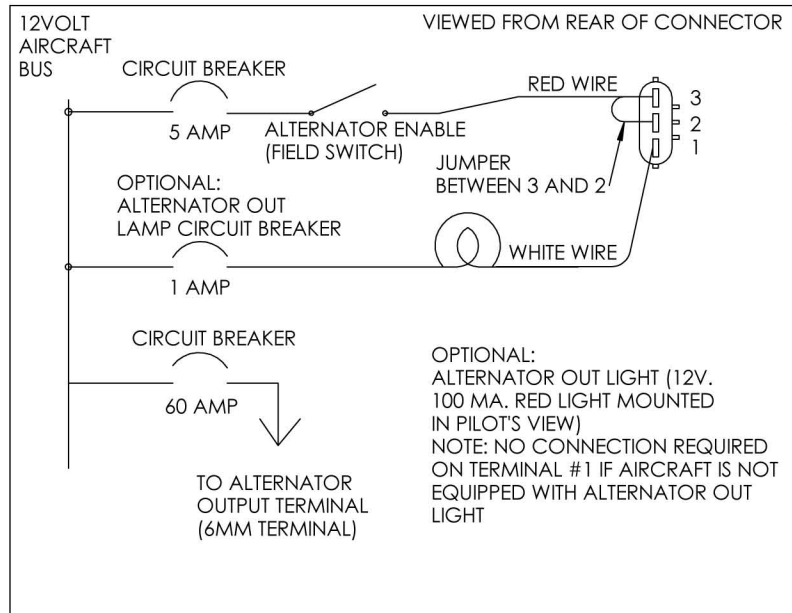
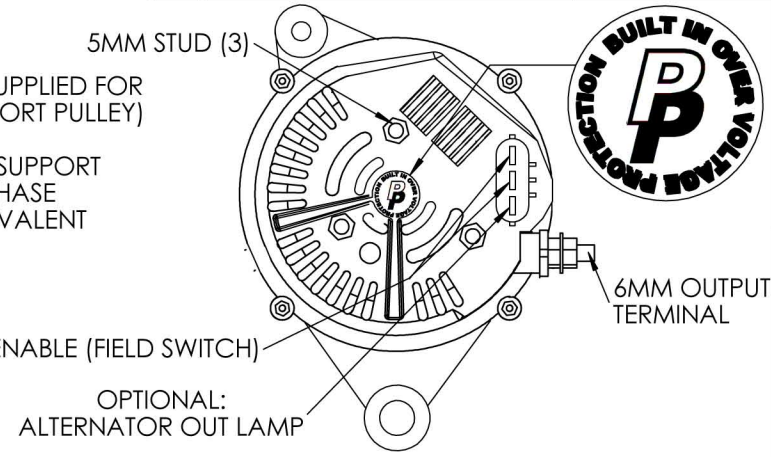
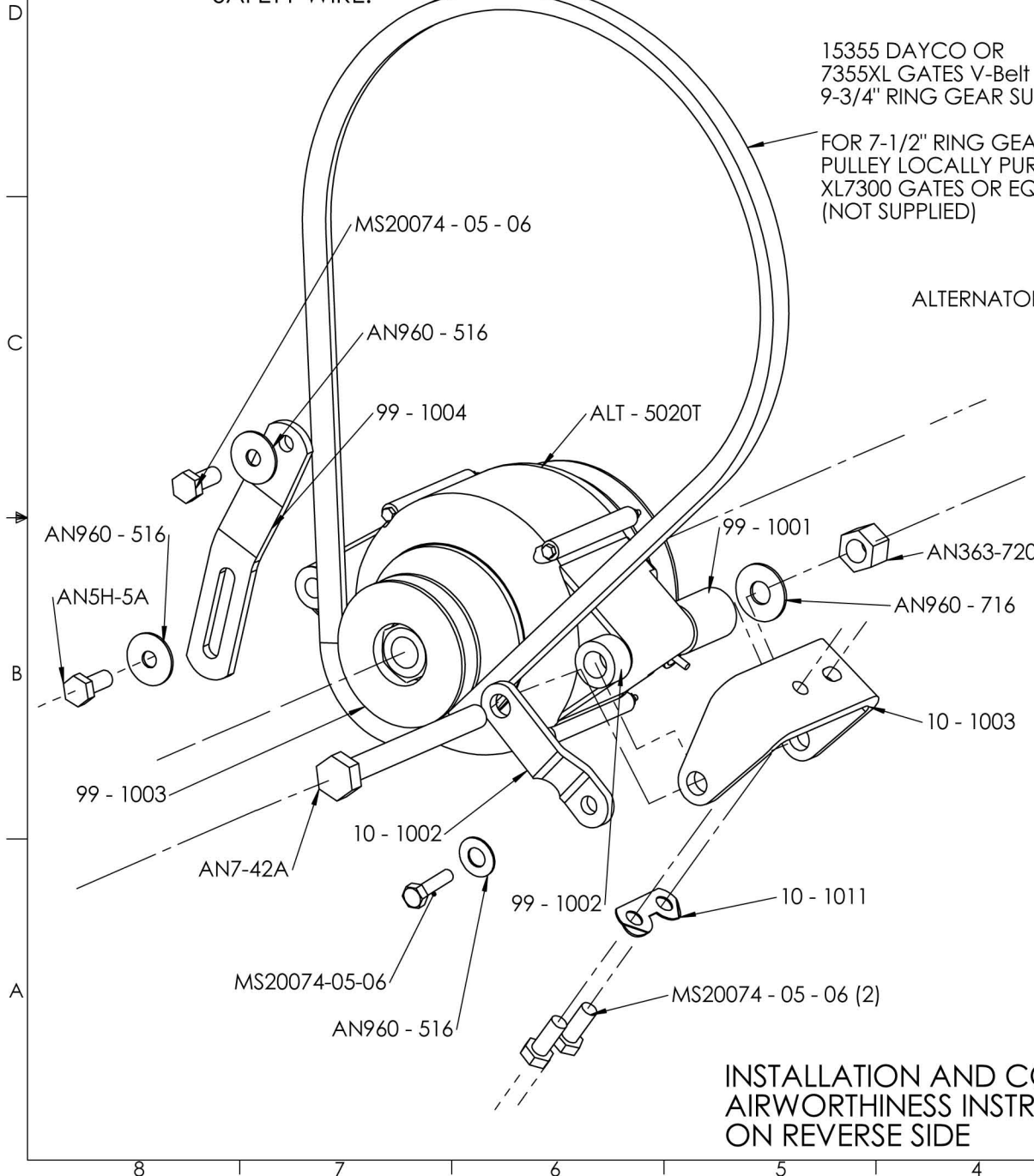

INSTALLATION AND CONTINUED AIRWORTHINESS INSTRUCTIONS ON REVERSE SIDE

PLANE POWER, LTD.
 GRANBURY, TEXAS

AL 12-EI60/B INSTALLATION INSTRUCTIONS

DRAWN BY: **B. JOWERS** DATE: **7/11/05**

MATERIALS: DWG. NO. **99 - 9900B** REV. **E**

Part No. 99-9900

Installation Instructions

1. Disconnect aircraft battery.
2. Install alternator per included drawing. Supply outside ram air to rear of alternator by the use of 1" scat tube or other suitable ducting.
3. Refer to appropriate engine service manual for belt tension and bolt torques.
4. Install battery wire with MS25171-2S terminal nipple on 6mm output terminal and torque to 50 in. lb.
5. Install connector in rear of alternator and wire in accordance with diagram on front of drawing
6. Reconnect aircraft battery.
7. Start engine, enable alternator and check for proper buss voltage.

Troubleshooting Instructions

Alternator is equipped with an internal crowbar over-voltage protection circuit which will disable alternator if an over-voltage condition is sensed.

If 5-amp enable circuit breaker trips from an over-voltage condition in the alternator:

1. Reset 5-amp enable circuit breaker and continue operation.
2. If 5-amp enable circuit breaker trips again, land as soon as possible and investigate cause.

Instructions For Continued Airworthiness

Annual Inspection:

1. Remove drive belt and turn alternator rotor to check condition of bearings for abnormal noise or roughness.

5 year or 700 hour intervals:

1. Repeat: Annual Inspection.
2. Remove field brush assembly and inspect brushes for excess wear. Replace brush assembly if brushes extend less than .250" from edge of brush holder case.