

NOTE: IF EQUIPPED WITH OFFSET TENSION ARM, SAFETY WIRE (2) TENSION ARM BOLTS (MS20074 - 05 - 10 & AN5H-5A), OR IF EQUIPPED WITH STRAIGHT TENSION ARM, SAFETY WIRE TENSION ARM BOLT (AN5H-7A) WITH .032" SAFETY WIRE.

REVISIONS

LTR.	DESCRIPTION	DATE	APR.
B	ADDED NOTE	6/06/05	SJK
C	CHANGED BOLT LENGTH & INSTALLATION INSTRUCTIONS	6/16/05	SJK
D	UPDATED PMA TAG	8/12/05	SJK
E	COMPANY NAME CHANGE	8/17/05	SJK
F	ADDED PART TAG DIM. & LOC.	9/09/05	SJK
G	CORRECTED NAMEPLATE	1/17/06	SJK

D
C
B
A

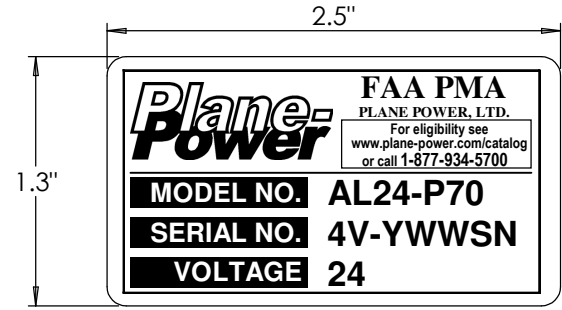
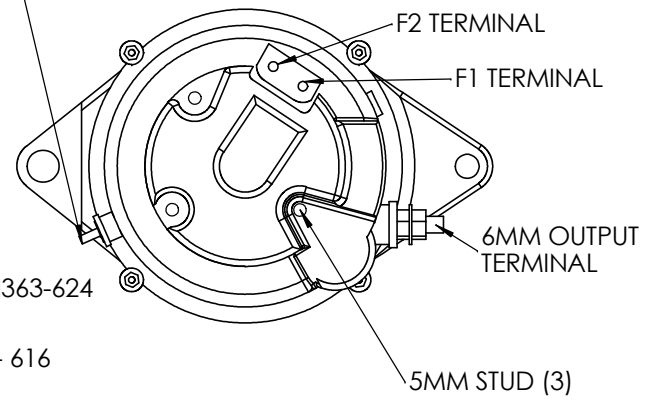
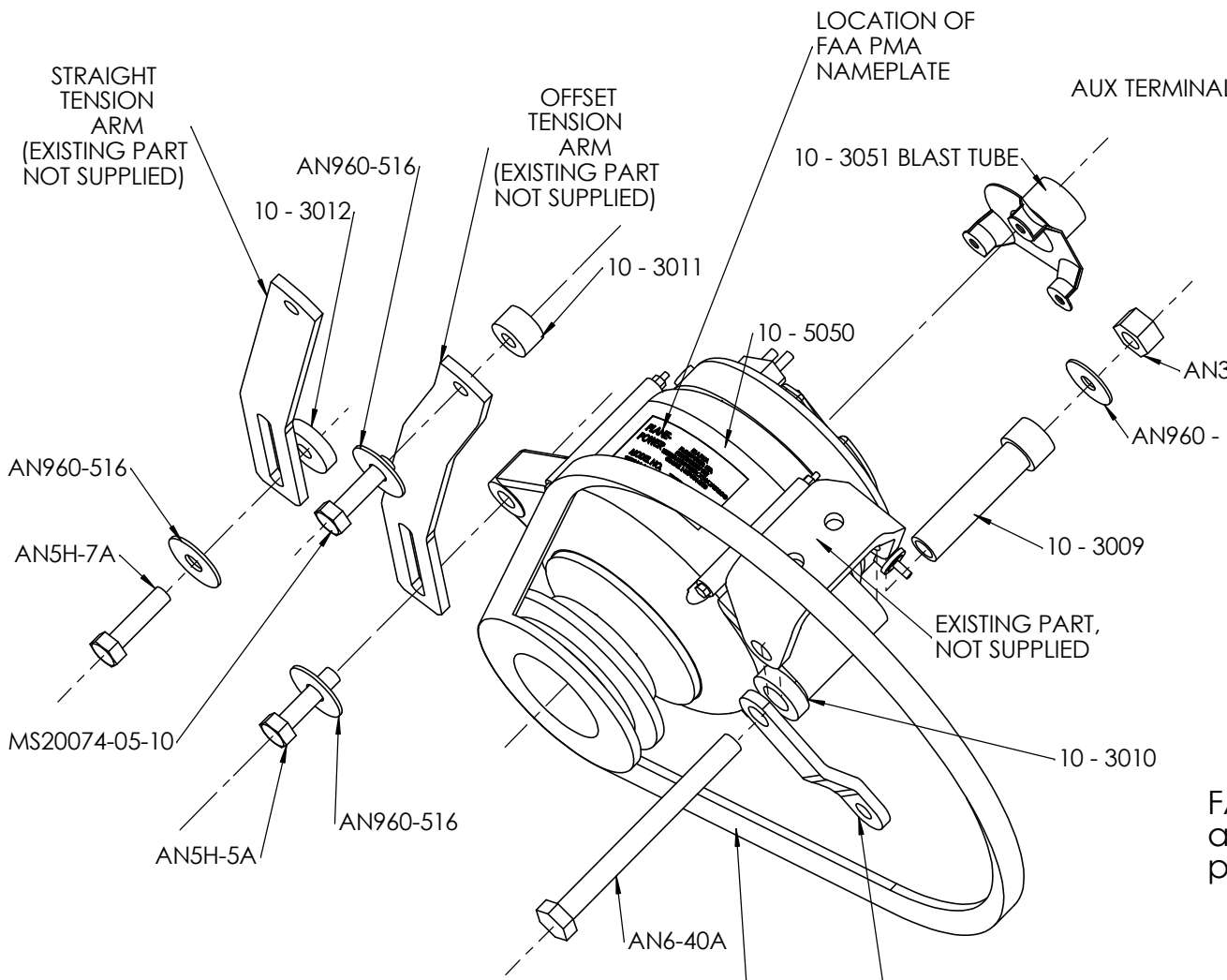

FAA PMA nameplate material to be adhesive backed Silver Polyester with permanent thermal print

INSTALLATION AND CONTINUED AIRWORTHINESS INSTRUCTIONS ON REVERSE SIDE

PLANE POWER, LTD. GRANBURY, TEXAS		
AL 24 - P70 INSTALLATION INSTRUCTIONS		
DRAWN BY:	B. JOWERS	DATE: 2/15/05
MATERIALS:	DWG. NO. 10 - 6001	REV. G

8 7 6 5 4 3 2 1

8 7 6 5 4 3 2 1

Part No. 10-6001

Installation Instructions

1. Disconnect aircraft battery.
2. Install alternator per included drawing.
3. Refer to appropriate engine and airframe service manuals for belt tension and bolt torques.
4. Install battery wire with MS25171-2S terminal nipple on 6mm output terminal and torque to 50 in. lb.
5. Install ground wire to any of the three 5mm studs on rear of alternator and torque to 35 in. lb.
6. Install field wire with MS25171-1S terminal nipple to F1 terminal on rear of alternator and torque to 20 in. lb.
7. NOTE: F2 terminal to remain grounded with ground strap UNLESS aircraft voltage regulator is a type "A" regulator using a 2-wire field circuit, in this case remove and discard ground strap from F2 terminal and connect wiring from voltage regulator to F1 and F2 terminals, torque to 20 in. lb.
8. If aircraft is equipped with an "alternator out light" circuit, connect that wire to the AUX terminal and torque to 20 in. lbs. Other wise leave AUX terminal open.
9. Reconnect aircraft battery.
10. Start aircraft and check alternator output for proper operation.

Instructions For Continued Airworthiness

Annual / 100 hour inspections:

1. Remove drive belt and turn alternator rotor to check condition of bearings for abnormal noise or roughness.

5 year or 1,000 hour intervals:

1. Repeat: Annual / 100 hour inspection.
2. Remove field brush assembly and inspect brushes for excess wear. Replace brush assembly if brushes extend less than .250" from edge of brush holder case.